

Short description torque transducer TTT01-P

The TEQFORT GmbH develop, produce and marketed on strain gauge based sensors for force and torque measuring as well as the required electronic. The name TEQFORT represent for - Test Equipment Force Torque - and for quality at high and highest precision.

The torque transducer of the model range TTT01-P is particularly well suited for all requirements in the field of non-rotating measurements. Especially for measuring tasks, where a high precision measurement at high bandwidth is required, it is characterized. Due to its construction with threaded flange, this model range can be very well built with our force transducer **FFB01-P** to a force / torque combination.



- Nominal load 10 Nm – 500 Nm
- For static and dynamic Application
- Accuracy 0,05 %
- Fatigue resistant up to ± 80 % (100 %) nominal load
- Against parasitic forces and bending moments insensitive

Short description torque transducer TTT01-P

The model TTT01-P can be used directly or via various adapters flexibly. The various loads of the program as well as versions in 1 mV / V, for dynamic applications up to 100% nominal load, make this torque sensor so versatile. The combination of size and accuracy distinguishes our model TTT01-P in such a way that it can be used in the most diverse applications of the automotive, railway, aerospace and even medical technology sector.



Options

Second measuring circuit for redundancy

Bending measuring circuits for M_x and M_y

Various add-on parts for mounting and introduction of torque loads

Direct connection with model FFB01-P to a force / torque combination

Technical Data

Nominal load	$\pm M_{nom}$	Nm	10	20	50	100	200	500
Accuracy		%	0,05					
Linearity error	d_{lin}	%	0,05					
Measuring range		%	1 – 100					
Hysteresis	h	%	0,05					
Interpolation error	f_c	%	0,4					
Reversibility error	v	%	0,2					
Reproducibility		%	0,003					
Zero-point deviation	f_0	%	0,5					
Creep		%	0,025					
Characteristic value tolerance	d_c	%	0,2					
left-/ right-characteristic value difference	d_{LR}	%	0,2					
Nominal temperature range		°C	+ 10 - + 60					
Temperature effect on characteristic value	TK_C	%/10K	0,04					
Temperature effect on zero signal	TK_0	%/10K	0,025					
Rated characteristic value (1*)	C_{nom}	mV/V	1,5 (0,8)		2 (1)			
Input resistance	R_e	Ω	ca. 1000					
Range of supply voltage	$B_{U,G}$	V	5 – 15					
Protection class (EN 60529)		IP	54					

(1*) In the model range TTT01-P, all sensors can be carried out in a 1 mV/V or 0.8 mV/V version for dynamic applications.

Technical Data

Nominal load	$\pm M_{nom}$	Nm	10	20	50	100	200	500
Lateral force limit		kN	5	15	25	40	65	100
Torque limit		%	150					
Braking torque		%	> 300					
Bending moment limit	$M_{b\,zul}$	%	100					
Axial force limit	$F_{a\,zul}$		10	20	40	60	90	160
Permissible vibration stress		%	80 (100) ^{2*}					
Base resonance frequency	f_G	khz	30		40	50	30	40
Nominal torsion angle	J_{nom}	rad	0,01	0,018	0,013	0,011	0,009	0,007
Torsional rigidity	C_T	Nm/rad	1000	1111	3846	9090	22220	71428

(2*) At a nominal characteristic value of 1 mV/V or 0,8 mV/V a vibration stress of up to $\pm 100\%$ is applicable.

Measuring line connection



Options for connection and measuring line

Bayonet connection for rough weather and offshore area

Fixed line connection

Standard measuring line length 5 meters, other lengths individually

Extended temperature range of the sensor with measuring line available for temperatures up to 200 °C

Amplifier in the measuring line or in the connection housing, see **EAW01**

Options for adapters and mechanical coupling

Individual adapters for mechanical integration into measuring systems can be supplied

At a direct screwed connection with our force transducer **FFB01-P**, a force / torque combination can be built up, which can have multiple channels (e.g., M_z , F_z , M_x , M_y).

Sensor dimensions

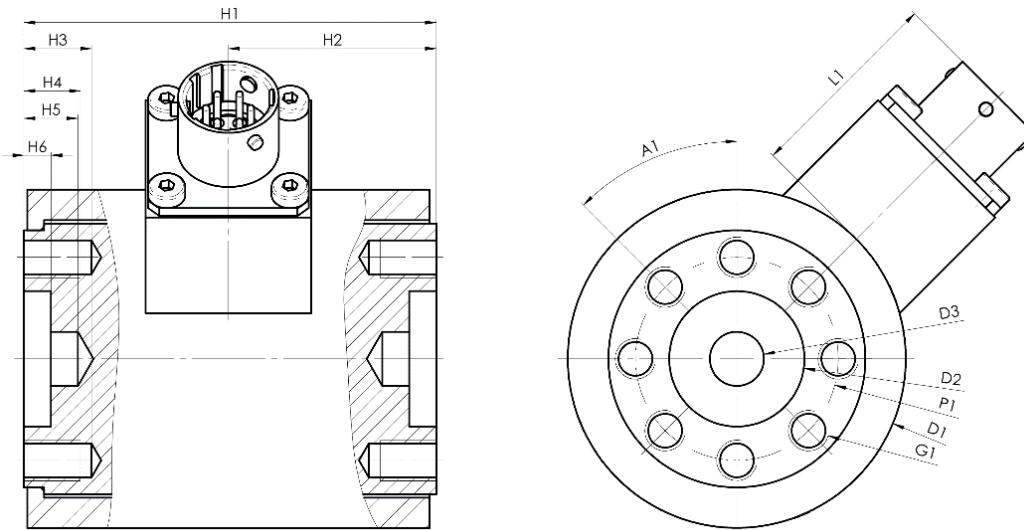

Nominal load	$\pm M_{nom}$	Nm	10	20	50	100	200	500
Height	H1	mm	61		82			
Height	H2	mm	30,5		41			
Height	H3	mm						
Height	H4	mm	8		15			
Height	H5	Mm	8					
Height	H6	mm	4					
Diameter	D1	mm	50		73			
Diameter	D2	mm	20 _{H7}		30 _{H7}			
Diameter	D3	mm	8 _{H8}		10 _{H8}			
Pitch circle diameter	P1	mm	30		45			
Thread	G1	mm	8 x M6		8 x M10			
Angle	A1		45°					
Length	L1	mm	30					
Mass, ca.		kg	0,5		1,6			

Version with redundant measuring circuit

For design with a second (redundant) measuring circuit, the same technical data apply as for the first measuring circuit.

Version with bending moment circuits

For design with bending moment circuits Mx and My, there will be two more full bridge strain gauge outputs, led out on the sensor housing.