

Ethernet via Telemetry

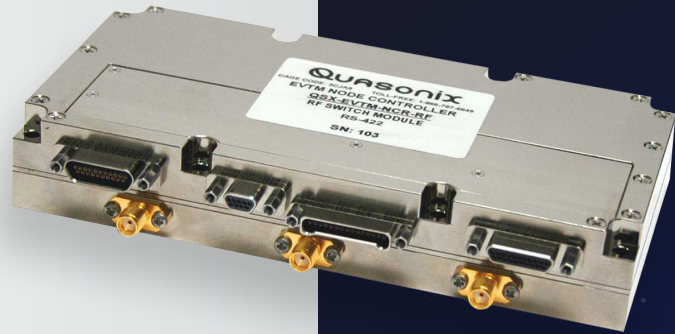

Redefine the “Local” in Local Area Network

With the Quasonix Ethernet Via Telemetry (EVTM) system, your test article can be on your ground station LAN, just like any other computer or Ethernet appliance. Connect cameras, Voice over IP, computers, and more, with a variety of hardware configurations to meet your needs. Quasonix is... Reinventing Telemetry™

High Speed Ethernet Traffic Over Telemetry Links – Ethernet telemetry data rates up to 40 Mbps using standard Ethernet protocols.

Enables Ethernet Data Transmission for a Wide Variety of Applications – Multimedia streaming, data source selection, data source isolation and forwarding, source rate and coding control in reaction to channel impairments, network extension, Voice over IP (VoIP), COTS based Ethernet products such as Industrial Control Sensor Devices and data recorders.

Supports all TCP/IP Packet Types – Streaming UDP packets, TCP connections, ICMP and SNMP messages are all passed over the air. (Connection-oriented traffic requires a bidirectional link.)

Time Division Duplex (TDD) or Frequency Division Duplex (FDD) Operation – TDD synchronizes from GPS clock standard, or Master Slave mode. TDD switching modules can be added to existing FDD hardware.

Optional COTS Devices Provide Tremendous Additional Capability – An industrial computer module between the data sources and the transmitter allows sophisticated control of the downlink traffic. Ethernet enabled data recorders provide an interface for legacy sensors.

Flexible, Comprehensive Solutions – EVTm can be added to existing systems or tailored to specific needs.

Contact Quasonix for a live video demonstration of EVTm and consultation on the right solution for you.

Possible Applications for EVTm

Control of COTS Camera Parameters Through the Ethernet Uplink – Control video resolution, video compression, camera direction, and more.

Source Control/Selection – Devices can be optionally enabled, disabled, and controlled either directly for Ethernet devices or via an Ethernet-enabled controller for devices without an Ethernet interface.

Transmitter Power Cycling Controls – For power-sensitive application, the ground controller can send messages to an air Ethernet-enabled controller to power the transmitter only when downlink data is required.

Network Extension – Isolated networks can be bridged over any terrain.

Diagnostics and Health Monitoring – The same status and error messages that maintain the Internet are available for monitoring and administration of the telemetry network. The Ground controller can monitor for transmitted network messages indicating link and link loss. GPS location data can be easily inserted into the downlink network traffic. Alarm, fault, and status messages can be multiplexed into the downlink stream using standard protocols (such as ICMP).

Encryption – The same security and encryption protocols available on the Internet become available over the telemetry link.

Data Isolation and Forwarding – Source data can be partitioned by its network destination address permitting the ground station to forward traffic only to the appropriate destination.



Packets appearing on the Quasonix transmitter's Ethernet port are available at the receiver's Ethernet port. To the end user, it's like having an Ethernet cable from the test article to the ground.

Advantages of EVTm over TmNS

EVTm	TmNS
Any band, any frequency	C-band only (designated center frequencies of 4900 MHz and 4922 MHz)
Any modulation in both directions	SOQPSK only
Any data rate in both directions	Same data rate in both directions, fixed at 13.3 Mbps
With or without LDPC - all six IRIG codes, or none	One code only (k=4096, r=2/3)
FDD and TDD operation	TDD operation only
User-defined transmit access schedule	Fixed 50/50 transmit access schedule
Does not require GPS to synchronize	Requires GPS (can result in very slow synchronization)
Mix and match EVTm modules with existing transmitters and receivers	Requires equipment specific to TmNS

EVTm Configuration Options

Test Article	
Transmit:	Quasonix Airborne EVTm Encoder/Decoder + any transmitter – Add Ethernet capabilities to existing airborne systems.
	Quasonix Ethernet-Enabled TIMTER™ Transmitter* – Ethernet or serial data in the same transmitter.
	Quasonix Airborne EVTm Node Controller + Quasonix transmitter – Allows TDD and FDD plus superior system control.
Receive:	Quasonix Airborne EVTm Encoder/Decoder + any receiver – Add Ethernet capabilities to existing airborne systems.
	Quasonix Ethernet-Enabled Compact RDMS™ Receiver – Ethernet or serial data in the same receiver.
	Quasonix Airborne EVTm Node Controller + Quasonix Compact RDMS receiver – Allows TDD and FDD plus superior system control.
Transmit and Receive:	Quasonix Airborne Ethernet-Enabled Modular Transceiver* – Allows unidirectional and bi-directional transmission and demodulation of encoded Ethernet data.

Ground	
Transmit:	Quasonix Ethernet-Enabled Rackmount Transmitter Platform* – Ethernet or serial data in the same transmitters (up to four per chassis).
Receive:	Quasonix 1U or 3U Rackmount RDMS Receiver – Ethernet or serial data in the same receiver.
Transmit and Receive:	Quasonix 1U Rackmount EVTm Encoder/Decoder – Add Ethernet capabilities to existing ground systems. One or two channels with separate Ethernet connections. Each channel allows both uplink and downlink data. Compatible with all receivers and transmitters.
	Quasonix 3U Rackmount EVTm Transceiver – Fully functional ground-station receiver with separate Ethernet connections for remote control and payload data.

* Minimum order quantities may apply

EVTM Encoder/Decoder

Airborne Encoder/Decoder

(Part Number QSX-EVTM-SED-AR-ET for RS-422, QSX-EVTM-SED-AT-ET for TTL)

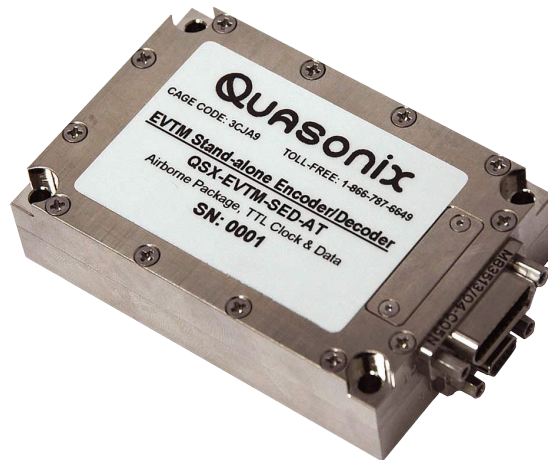

Rackmount Encoder/Decoder

(Part Number QSX-EVTM-1URX-1CH for 1 channel, QSX-EVTM-1URX for 2-channel)



Turn existing telemetry links into virtual Ethernet links. The Quasonix EVTm Encoder/Decoder – compatible with any transmitter or receiver – translates Ethernet packet data to serial streaming clock and data for input to transmitters. It also translates recovered serial clock and data from a telemetry receiver back to original Ethernet packets.

EVTm encoding and decoding is required at both ends of a link for operation. The Encoder/Decoder can support bidirectional data from a single piece of hardware.

Our EVTm Encoder/Decoders could not be simpler to operate. Connect them and power them on - that's it. No IP addressing or settings required. The telemetry transmit data rate is set by the encoder data buffer drain rate, and the receiver data rate is automatically set by the incoming clock from the telemetry receiver.

Airborne EVTm Encoder/Decoder Specifications

Electrical

Input Voltage 10-32VDC

Physical

Size 2" (W) x 3" (D) x 0.7" (H)

Weight 2.6 oz.

Power 1 W

Environmental

Storage Temperature -55° C to +100° C

Operating Temperature -40° C to +85° C

Operating Humidity 0-95% (non-condensing)

Vibration 20 G, 5 Hz to 2 kHz (all axes)

Acceleration 100 G (all axes)

Shock 100 G pk, half-sine, 5 ms (all axes)

Altitude Up to 100,000 ft.

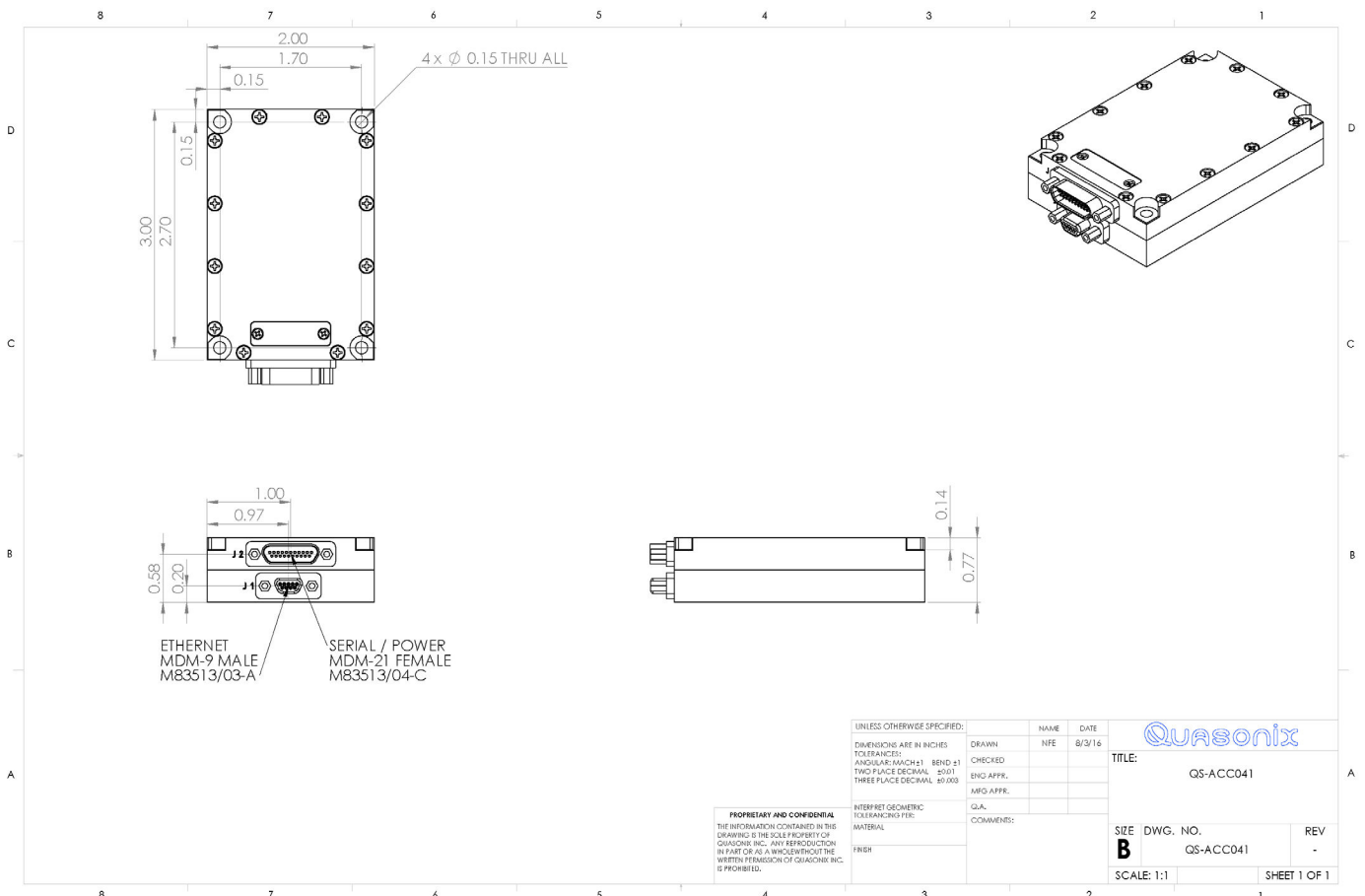

Airborne EVTm Encoder/Decoder Connectors

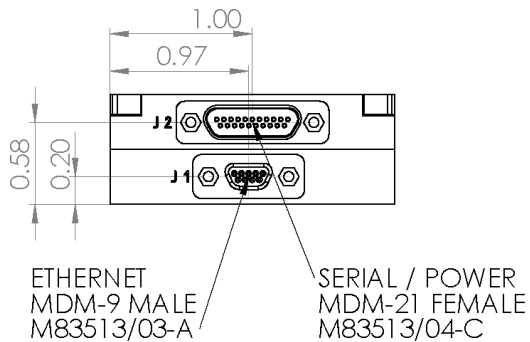

	Connector Number/Pin	Description
Transmit +	J1/1	Positive leg of a differential pair, transmit data onto Ethernet network; pin 1 on a standard (T568A) RJ-45
Receive +	J1/5	Positive leg of a differential pair, receive data from Ethernet network; pin 3 on a standard (T568A) RJ-45
Transmit -	J1/6	Negative leg of a differential pair, transmit data onto Ethernet network; pin 2 on a standard (T568A) RJ-45
Receive -	J1/9	Negative leg of a differential pair, receive data from Ethernet network; pin 6 on a standard (T568A) RJ-45
Transmit Clock +	J2/1	Serial streaming synchronous clock from encoder to telemetry transmitter
Transmit Data +	J2/2	Serial streaming data from encoder to telemetry transmitter
System Clock +	J2/3	Encoder data buffer drain rate clock; signal sets telemetry transmitter data rate
Power	J2/6	DC power into device +10-32 VDC
Receive Data +	J2/10	Serial streaming data from telemetry receiver to decoder
Receive Clock +	J2/11	Serial streaming synchronous clock from telemetry receiver to decoder
Transmit Clock -	J2/12	Serial streaming synchronous clock from encoder to telemetry transmitter
Transmit Data -	J2/13	Serial streaming data from encoder to telemetry transmitter
System Clock -	J2/14	Encoder data buffer drain rate clock; signal sets telemetry transmitter data rate
Ground	J2/16	DC power ground
Ground	J2/17	DC power ground
Receive Data -	J2/20	Serial streaming data from telemetry receiver to decoder
Receive Clock -	J2/21	Serial streaming synchronous clock from telemetry receiver to decoder

Color Legend

Male MDM-9*

Female MDM-21

* Pre-assembled MDM-9 Male to RJ-45 (T568A) cables are available from Quasonix.

Rackmount EVTm Encoder/Decoder Specifications

Electrical

Input Voltage	100-240 VDC 50-60 Hz
---------------	----------------------

Physical

Size	18.95" (W) x 15.5" (D) x 1.72" (H)
Weight	7.6 lbs.
Power	8 W

Environmental

Storage Temperature	-20°C to +70°C
Operating Temperature	0°C to +50°C
Operating Humidity	0-95% (non-condensing)

Rackmount EVTm Encoder/Decoder Connectors (Per Channel)



Connector	Description
Ethernet	Ethernet format data from network to transmitter, and from receiver to network; Ethernet ports are NOT connected to each other internally
J2/1	Serial streaming synchronous clock from encoder to telemetry transmitter
J2/2	Serial streaming data from encoder to telemetry transmitter
J2/3	Encoder data buffer drain rate clock; signal sets telemetry transmitter data rate
Clock to Transmitter	Serial streaming synchronous clock from encoder to telemetry transmitter
Data to Transmitter	Serial streaming data from encoder to telemetry transmitter
System Clock to Transmitter	Encoder data buffer drain rate clock; signal sets the telemetry transmitter data rate
Clock from Receiver	Serial streaming synchronous clock from telemetry receiver to decoder
Data from Receiver	Serial streaming data from telemetry receiver to decoder
Color legend:	RJ-45 75 Ω BNC

Airborne EVTMM Node Controller

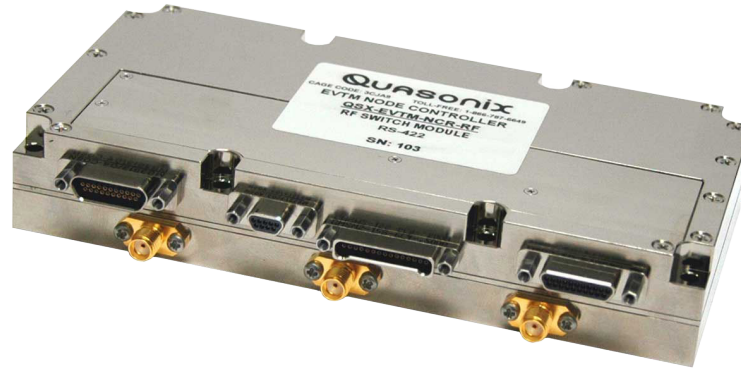

The EVTMM Node Controller allows for TDD (Time-Division Duplex) or FDD (Frequency-Division Duplex) operation. It includes smart router and data-flow controls (IP addressable) and is available with or without an RF switch module.

Browser based user interface with integrated transmitter and receiver control – Compact easy-to-use control panel look and feel; capable of controlling and monitoring both local and remote devices

Built in RF link packet testing capability – Built in wireless interface packet testing; control from local node controller browser user interface; provides test statistics for local and remote interface

Local and Remote link statistics monitoring – Monitoring of wireless transmit and receive packets from local or remote; low overhead remote statistics data embedded in transmit stream; configurable levels of statistics reporting

Wired to Wireless packet traffic management – Filter from the wireless transmit interface a set of Ethernet and/or IP packets that match packet rejection criteria; enable only a set of Ethernet and/or IP packets that match packet accept criteria; configure Multicast traffic streams to bridge from wired to wireless interface

Status

Device: ● Device

Statistics Reset All Statistics Details Logs

Rate: 12.23 Mbps 45%

	Local	Remote
Queue Latency	299 2	777 5

Dropped Packets

Queue	Local	Remote
Queue	7	0
RF	2	0
Total	9	0

Configuration | Monitor | Statistics | Logs | About

Device: Master Mode: Config Submit Refresh

Config: Default TA 1

Link Config | Radio Config | Traffic Gen

EVTMM Type: TDD

Link Type: TDD Time Sync

Schedule Master:

Nonscheduled Master ID: 2

Epoch Time (ms): 100

Epoch Slots: 10

Scheduled Slots: 1

Guard Time (ms): 1

Nonscheduled Masters: 1

Network Bridge Enabled:

Presets

Preset Title	Description	Save Config
Default	Master:Default TA 1	Export Load
Default	Non-Master:Default Ground 1	Export Load

EVTMM Browser Interface

EVTM Node Controller Specifications

Electrical

Input Voltage 10-32VDC

Physical

Size 6" (W) x 3" (D) x 1" (H)

Weight 17.9 oz.

Power 10 W

Environmental

Storage Temperature -55° C to +100° C

Operating Temperature -40° C to +70° C

Operating Humidity 0-95% (non-condensing)

Vibration 20 G, 5 Hz to 2 kHz (all axes)

Acceleration 100 G (all axes)

Shock 100 G pk, half-sine, 5 ms (all axes)

Altitude Up to 100,000 ft.

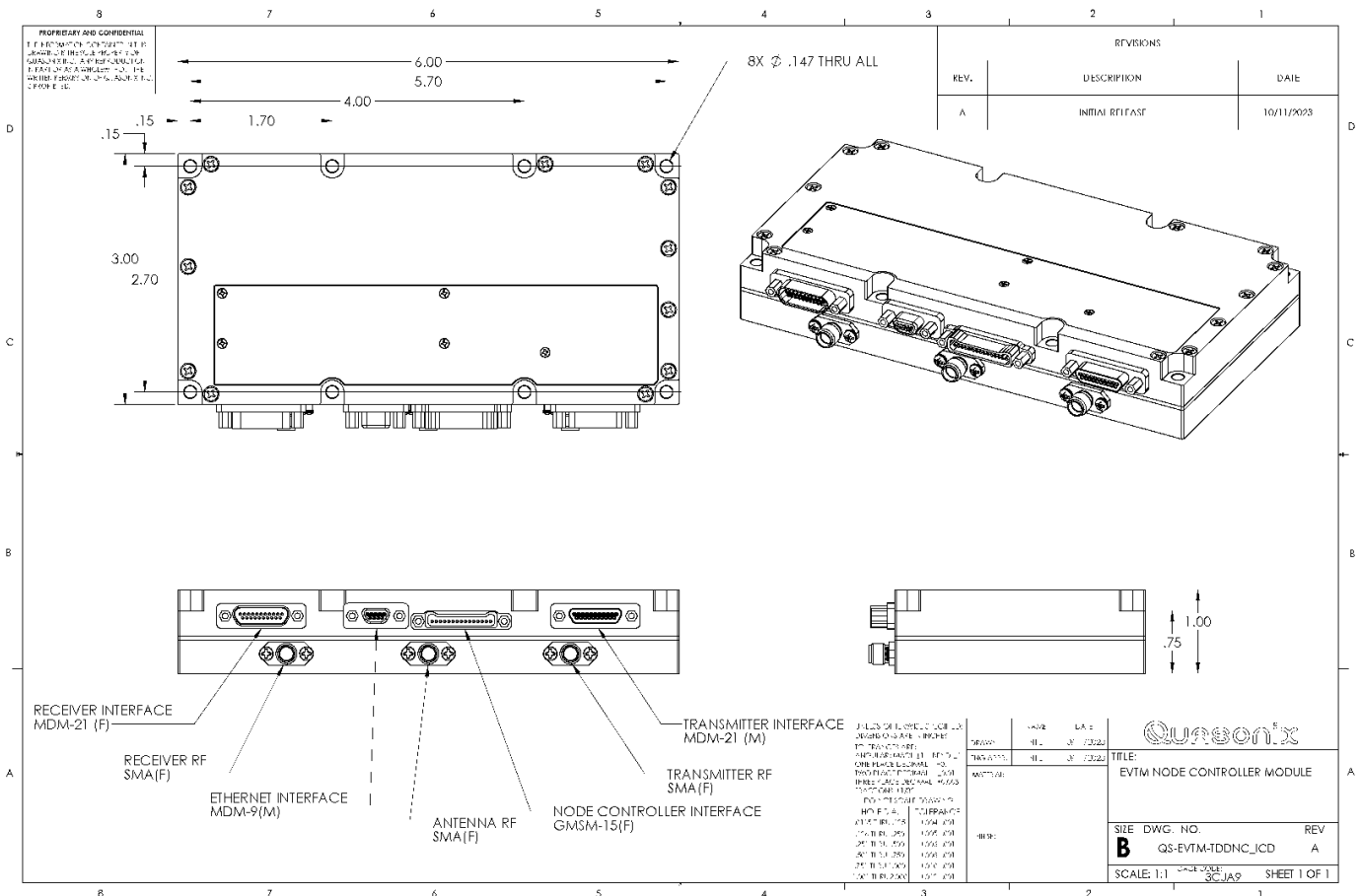

EVTM Node Controller Connectors

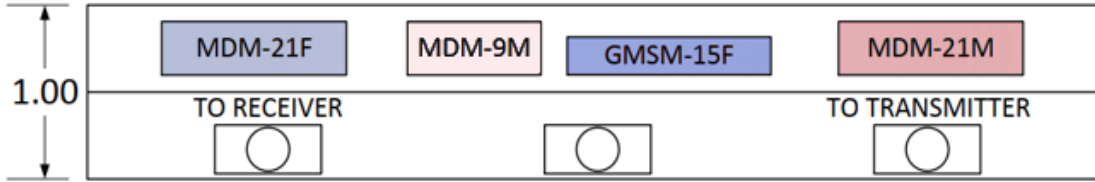

	Ethernet	To Receiver	To Transmitter	Main
	Pin	Pin	Pin	Pin
TX+	1	-	-	-
RX+	5	-	-	-
TX-	6	-	-	-
RX-	9	-	-	-
Clock +	-	4	4	-
Data +	-	5	5	-
Clock -	-	15	15	-
Data -	-	16	16	-
RS-232 RXD	-	18	18	3
RS-232 TXD	-	8	8	1
RS-232 GND	-	6	6	-
Lock Detect	-	7	-	-
T/R to RX	-	14	-	-
T/R to TX	-	-	7	-
Ones Detect	-	17	17	-
CG +	-	-	3	-
CG -	-	-	14	-
T/R In +	-	-	-	4
T/R In -	-	-	-	5
T/R Out -	-	-	-	12
T/R Out -	-	-	-	13
IRIG-B	-	-	-	15
+28 VDC	-	1	1	7
+28 VDC	-	12	12	8
+28 VDC	-	-	-	9
GND	-	2	2	2
GND	-	3	13	6
GND	-	13	-	10
GND	-	-	-	14

Color legend:	Male MDM-9	Female MDM-21	Male MDM-21	Female GSM-15
---------------	------------	---------------	-------------	---------------

EVTM Node Controller Part Numbering

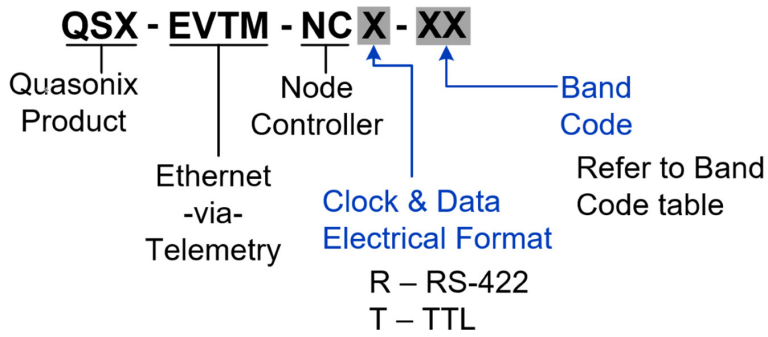

Band Selection (T/R Switch Module)

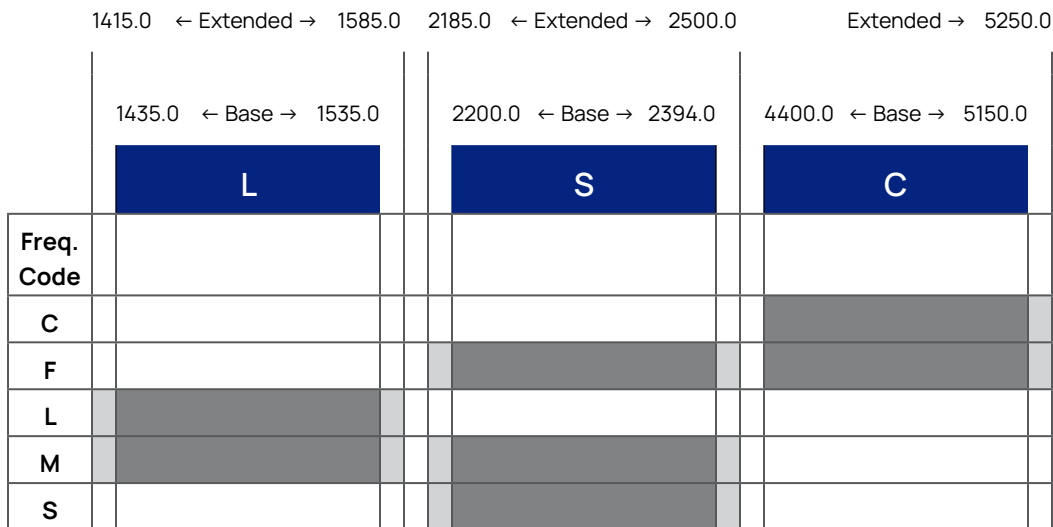

- Frequency Gap
- Standard (Base) Frequency Range
- Extended Frequency Range
(available by selecting Extended Tuning = 1 in part number)

Ethernet-Enabled Transmitters, Receivers, and Transceivers

Built on proven TIMTER transmitter and RDMS receiver hardware, these Ethernet-enabled units include connections to interface with Ethernet data and processors to handle encoding/decoding. As a result, every Quasonix Ethernet-enabled transmitter or receiver can be used for processing either encoded IP data or serial streaming telemetry data, offering flexibility of deployment. Regardless of how you use them, you know you'll have dependable units that are easy to set up and operate for years to come.

Specifications for transmitters and receivers are provided in their respective datasheets.



Ethernet-Enabled Transmitter*



Ethernet-Enabled Compact Receiver

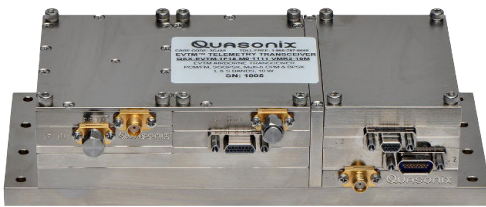

Ethernet-Enabled Airborne Modular Transceiver*



Ethernet-Enabled 3U Rackmount Transceiver



Ethernet-Enabled 3U Rackmount Receiver



Rackmount Transmitter Platform, * capable of supporting up to four Ethernet-Enabled Transmitters

* Minimum order quantities may apply

QUASONIX

All Quasonix products are under U.S. Dept. of Commerce jurisdiction. Receivers are categorized as 5A991.
ISO 9001:2015 Certified | Specifications subject to change without notice.

6025 Schumacher Park Drive West Chester, OH 45069 | 1-513-942-1287 | www.quasonix.com

**Instrumentation
Devices**

Instrumentation Devices Srl
Via Acquanera 29 - 22100 COMO (Italy)
ph +39 031 525 391- fax +39 031 507 984
info@instrumentation.it - www.instrumentation.it